

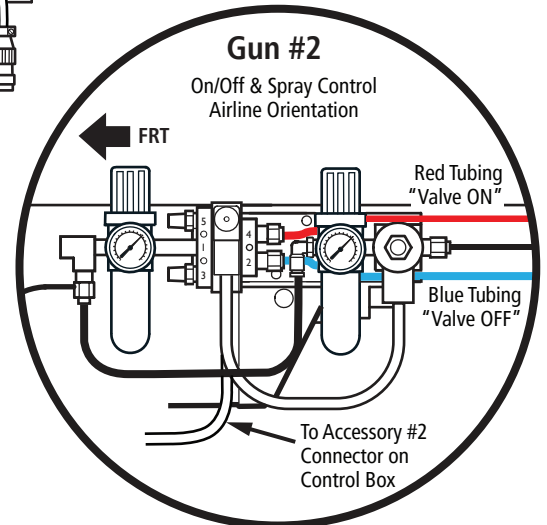

# Automatic Gun On/Off & Spray Pattern Control

**IMPORTANT:** The illustration below shows the red and blue air line orientation for "Gun #1." The red and blue air line orientation for "Gun #2" is reversed as shown.

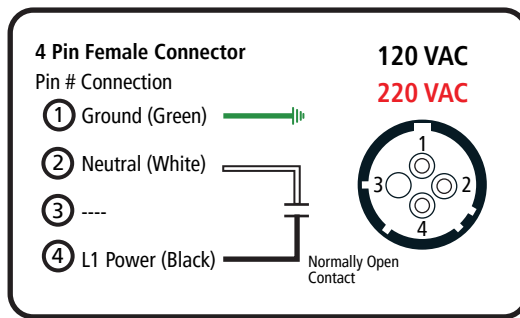
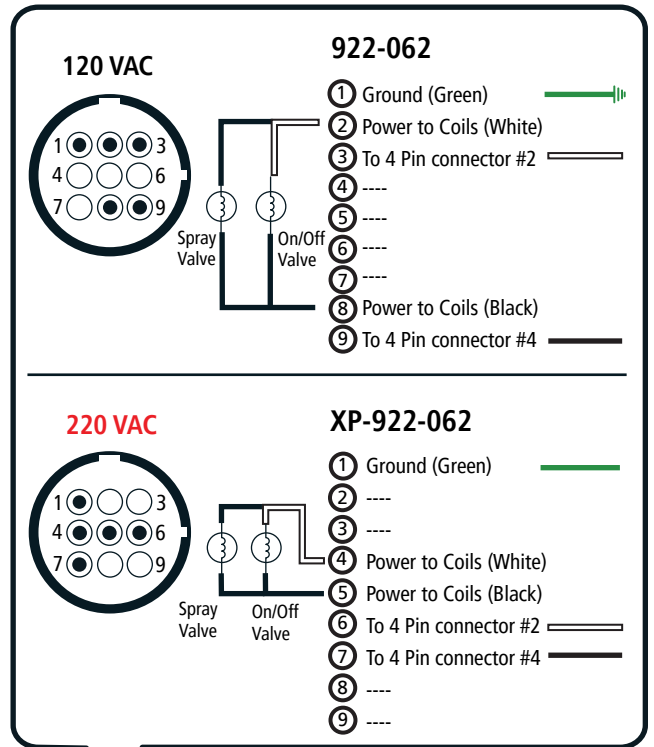
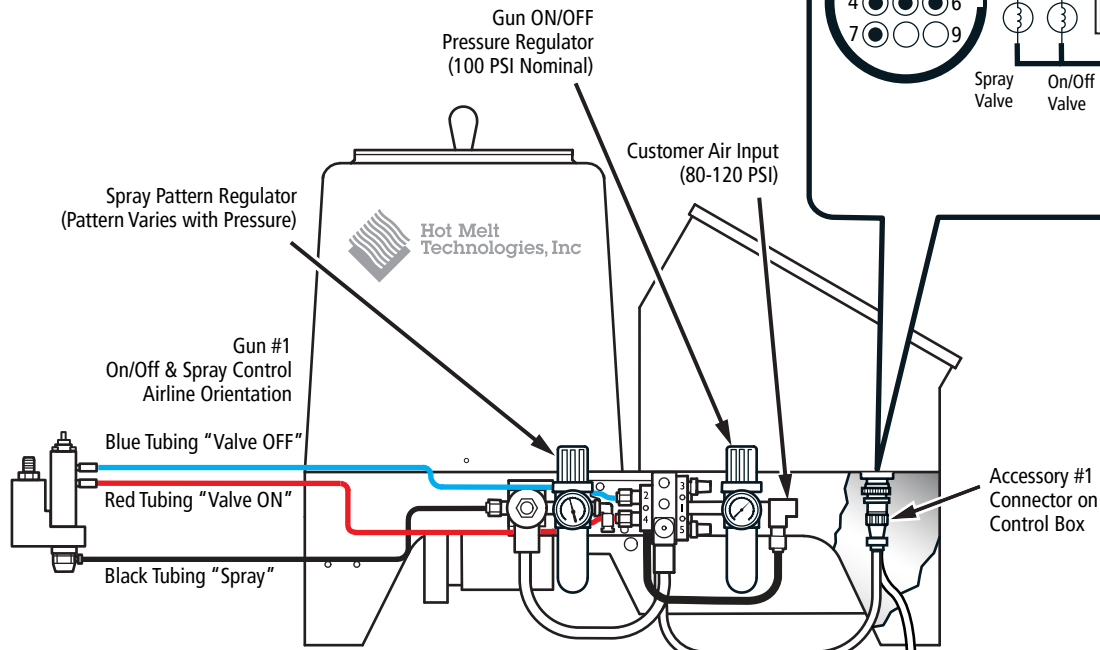

See reverse for switch options





# Automatic Gun On/Off & Spray Pattern Control

922-062  
XP-922-062

The Hot Melt swirl spray pattern is controlled by using an air regulator and solenoid that delivers pressurized air through an air line on the heated hose, to a spray nozzle attached to the gun.

All Hot Melts do not spray alike. Each material will require specific temperature, fluid, air and nozzle adjustments to provide the desired swirl spray pattern.

### To adjust the Spray Pattern

1. Increase or decrease the air flow by adjusting the Air Regulator on the Spray Pattern Control.
  - ▶ Turn Clockwise to increase.
  - ▶ Turn Counter-Clockwise to decrease
2. Increase or decrease the adhesive flow by adjusting the Flow Control Knob.
  - ▶ Turn Clockwise to increase.
  - ▶ Turn Counter-Clockwise to decrease
3. Changing the gun's Fluid Nozzle and/or Spray Insert can vary the spray pattern throughout a wide range.
  - ▶ For options see Nozzle page or contact us.

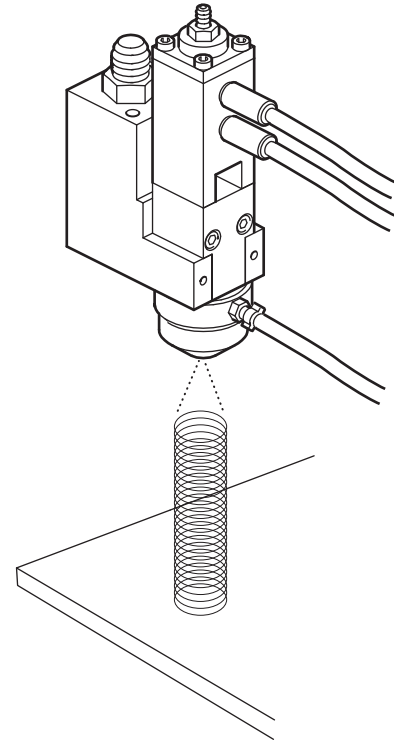

**Note:** There is a direct relationship between the glue flow, the air pressure, and the resulting spray pattern.

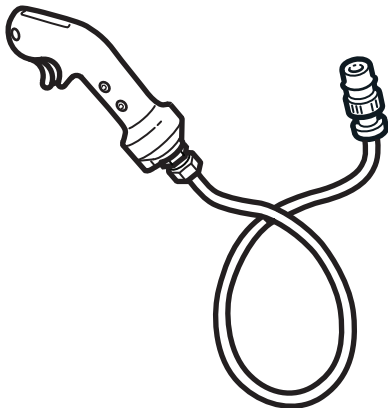

Remote Trigger Switch  
**922-044**

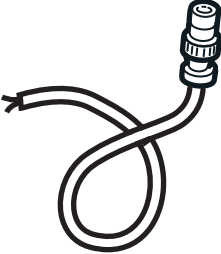

Remote Run Cable  
for OEM Interface  
**922-041**

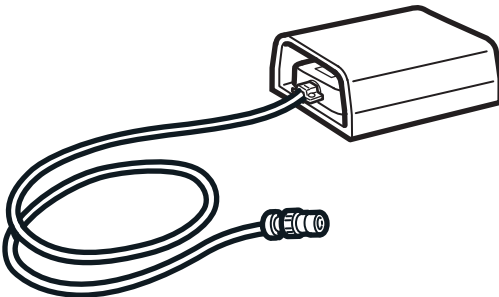

Foot Switch  
**922-045**

Contact Closure Activates Motor and Valve Simultaneously

