

# BENCHMARK 650

High Performance System

I.G. Sealant System

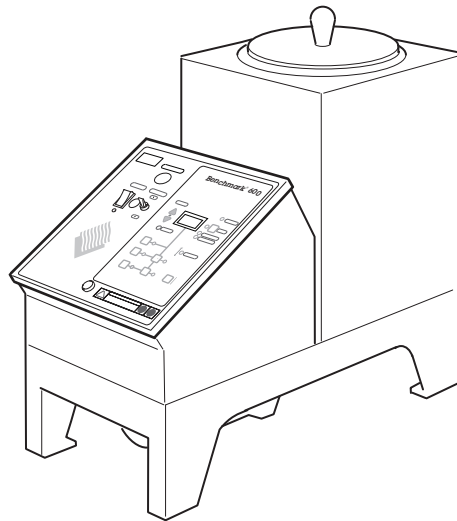

### Standard Features

- ▶ Manual Standby
- ▶ Auto-Standby, Auto-Off Timer
- ▶ Microprocessor Temp Control
- ▶ All Zone Temp Readouts
- ▶ Patented Modular Melt Tanks
- ▶ Power Cord
- ▶ Hardened Steel Gear Pumps
- ▶ High Torque AC Drive Motor
- ▶ Precision Flow Control

### Common Options

- ▶ #340-032 Key Lock
- ▶ #910-100 Load Alert
- ▶ #921-011 Steel Cart

### Benchmark Melt Unit 220v

DESCRIPTION	PART NUMBER P/N#	TANK CAPACITY (APPROX.)	HOSE/GUN CAPABILITY
BM650	BM650-W-F4	50 lbs.	1

### Handguns 220v

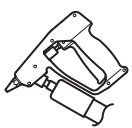

CONFIGURATION	Standard Entry 
PART NUMBER #	XP-403-RS

### Heated Hoses 220v

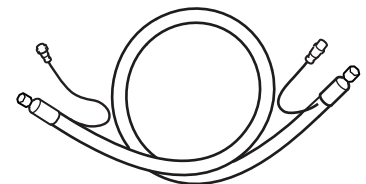

HOSE LENGTH	REGULAR HOSE P/N#
8 Ft.	XP1008-HF
12 Ft.	XP1012-HF
16 Ft.	XP1016-HF



### Insulated Glass Gunning Tips Solid Brass

PART NUMBER #	ORIFICE
156-098 	Tip Seat
IG-3 	3/16" Bead
IG-4	1/4" Bead
IG-5	5/16" Bead
IG-6	3/8" Bead
IG-7	7/16" Bead
IG-8	1/2" Bead
IG-10	5/8" Bead
IG-12	3/4" Bead

### Standard Bead Extrusion Nozzles

PART NUMBER #	ORIFICE
156-022 	.090
156-047 	.090

Effective Date: 1/1/2018

All prices are subject to change without notice

©2018 Hot Melt Technologies, Inc

