

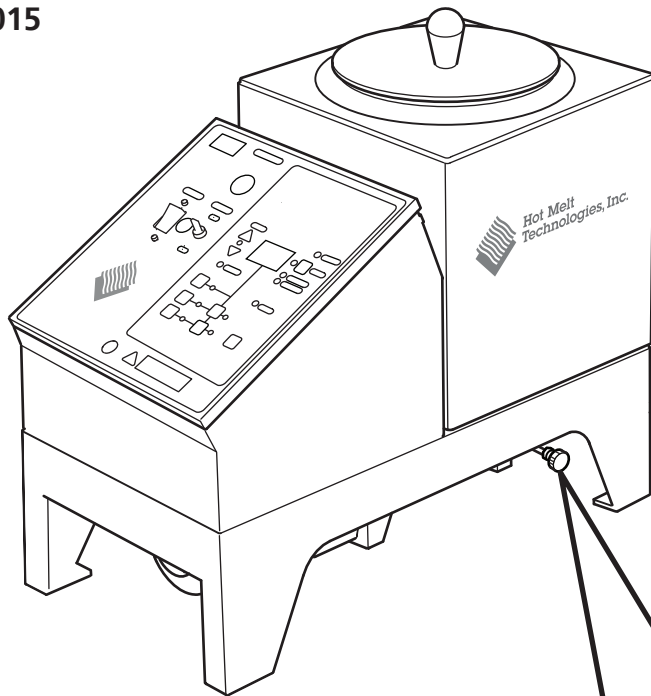

# DFS Accu-Flow™

940-015



### Flow Control Instructions

- ▶ To increase adhesive flow, turn knob clockwise.
- ▶ To decrease adhesive flow, turn knob counter clockwise.
- ▶ It is possible to remove the adjustment knob and screw assembly if turned fully counter-clockwise.



Avoid turning clockwise past maximum flow. Motor stall and/or damage can occur.

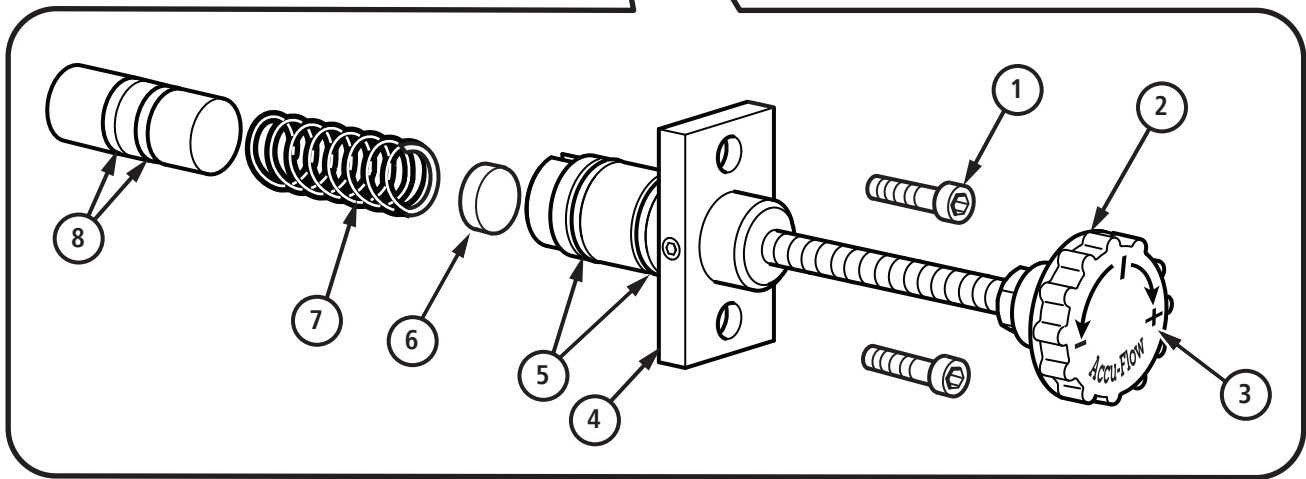

### BILL OF MATERIALS

ITEM	DESCRIPTION	PART NO	QTY
1	1/4-20 × 1/2" Socket Head Screw Cap	322-101	2
2	Adjustment Knob and Screw Assembly	940-013	1
3	Decal	340-244	1
4	Retainer Plate	400-023	1
5	O-Ring	520-008	2
6	Flow Control Back Up Plate	400-007	1
7	Flow Control Spring	400-006	1
8	O-Ring	520-023	2

