

PROFLEX G6
Pre-Melter System
220v, 3ph

Standard Features

- ▶ Auto-Standby
- ▶ Auto-Off Timer
- ▶ Ready Delay Timer
- ▶ Manual Standby
- ▶ Set Point Limit
- ▶ Front Panel Diagnostics
- ▶ All Zone Ready
- ▶ Temp Readout, °F or °C
- ▶ ±1°F Temp Control
- ▶ Hose/Gun On/Off Control
- ▶ 2 or 4 Hose/Gun Capability
- ▶ Audible Fault Alarm
- ▶ Service Clock
- ▶ Pump On/Off Control
- ▶ Precision Flow Control

Common Options

- ▶ #340-032 Key Lock
- ▶ #934-247 24h/7d Timer
- ▶ #921-014 Steel Cart Assembly
- ▶ #921-017 Base Cart
- ▶ #XP-922-221 OEM Interface Cable
- ▶ #XP-922-040 Remote Motor Run Cable
- ▶ ProFill Load Alert

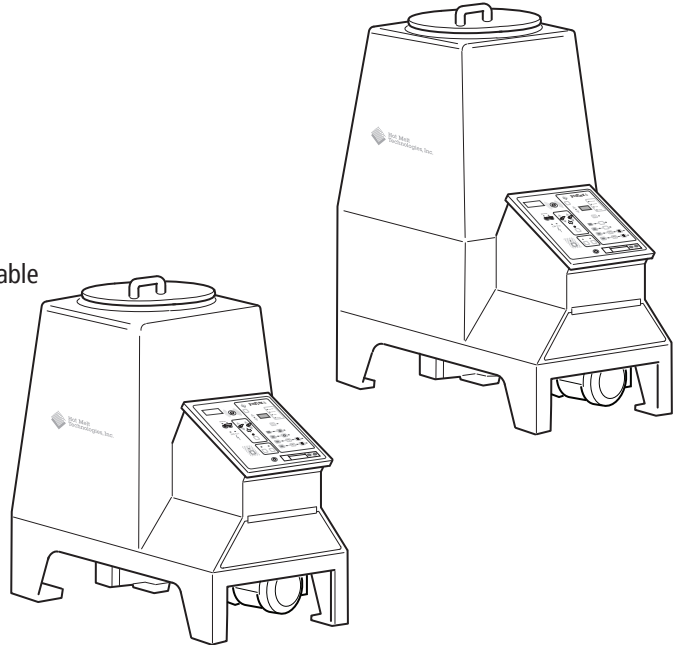

System Configuration

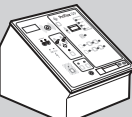
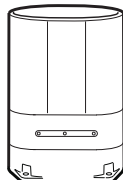
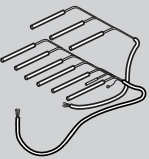
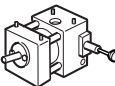
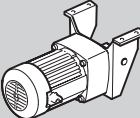
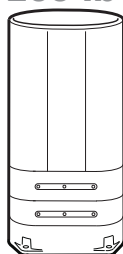
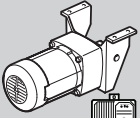
G6 - XXX - W - 50 - X - X - 3P						
CONTROL PACKAGE	TANK SIZE	TANK HEATER HARNESS	PUMP	MOTOR		
	135 lb 			 CONSTANT SPEED F - 113 RPM, 1/3 HP K - 170 RPM, 1/3 HP	SINGLE "1"	240v, 3ph "3P"
	200 lb 			 VARIABLE SPEED A - AC 0-125 RPM G - DC 0-125 RPM	Dual "2"	

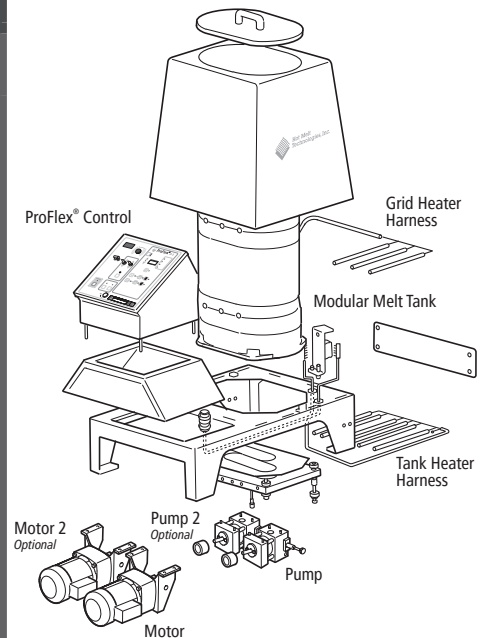

Effective Date: 7/22/19

All prices are subject to change without notice

©2019 Hot Melt Technologies, Inc

