



Hot Melt Adhesive

Typical Physical Properties

- ▶ Typical Application Temperature Range: 325°F – 375°F
- ▶ Viscosity: 900 – 1200 cps @ 350°F
- ▶ Softening Point: Approx. 230°F
- ▶ Color: Yellow to Amber Solid

General Uses and Product Characteristics

HMT-1269 is a member of our 1200 Series Benchmark general purpose EVA based adhesives. These products have high flexibility and good hot tack. They show excellent pot life of up to 100 hours with very little polymer degradation. They provide high strength bonds to various substrates ranging from paper and paperboard products, plastics, as well as wood composite substrates.

Storage and Handling Suggestions

Store in cool, dry place in the original shipping container only. Keep container closed and tightly sealed when not in use to avoid contamination.

Clean-up and Safety Information

For purging, use HMT's 1200-HMP purge compound. To minimize the risk of burns, we recommend the use of eye protection and protective clothing when working near the hot melt applicator.

Packaging Information

Package changes can occur without notice.

- Approx. Pallet Dimensions: L=48", W=40", H=51"
- Full Pallet Weight: 1200 lb Net (40 boxes)
- Rows per Full Pallet: 4
- Weight per Row: 300 lb Net (10 boxes)

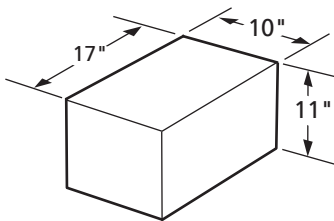

- Container Type: Box
- Container Dimensions: L=17", W=10", H=11"
- Container Weight: 30 lb Net

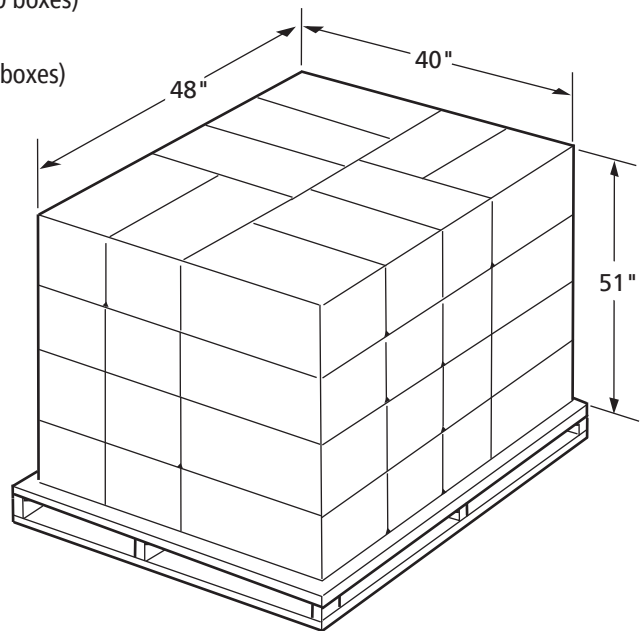

1269

Chemistry

Synthetic Resin

Form

Pillows

Shelf Life

One year from the date of shipment.

All raw materials used in the manufacturing of 1269-PS are approved according to FDA guidelines 175.105 for food packaging.

Standard Disclaimer

The data presented is based on tests standard to the adhesive industry. Because we have no control over the application process or the substrates used by the customer, HMT can not certify the performance of the assembly the adhesive is used on. HMT will assume no responsibility for results obtained or for incidental or consequential damages arising from the use of this adhesive.



Hot Melt Technologies, Inc.
No One Puts It Together Like HMT[®]