



Hot Melt Sealant

Typical Physical Properties

- ▶ Handgun Application Temperature Range: 365°F – 385°F
- ▶ MVTR 100° F/98% RH 60MIL: 0.65g/m2/day
- ▶ Approximate Pounds per Gallon: 9.8
- ▶ Color: Black

General Uses and Product Characteristics

HMT-8203 is a single component, 100% Hot Melt Butyl sealant designed for the insulated glass industry. It provides outstanding adhesion to glass and aluminum. The product is formulated to meet ASTM E2190 and is resistant to degradation from ultraviolet light, temperature extremes and water immersion. Is not intended for structural glazing applications. Should not be used if the IG is unframed or unsupported.

Storage and Handling Suggestions

Store in cool, dry place in the original shipping container only. Keep container closed and tightly sealed when not in use to avoid contamination.

Clean-up and Safety Information

For purging, use HMT's Green-Kleen purge compound. To minimize the risk of burns, we recommend the use of eye protection and protective clothing when working near the hot melt applicator.

Packaging Information

Package changes can occur without notice.

Approx. Pallet Dimensions: L=48", W=40", H=51"
 Full Pallet Weight: 1600 lb Net (32 boxes)
 Rows per Full Pallet: 4
 Weight per Row: 400 lb Net (8 boxes)

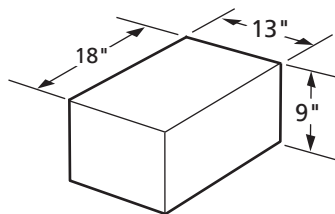

Container Type: Box
 Container Dimensions: L=18", W=13", H=9"
 Container Weight: 50 lb Net

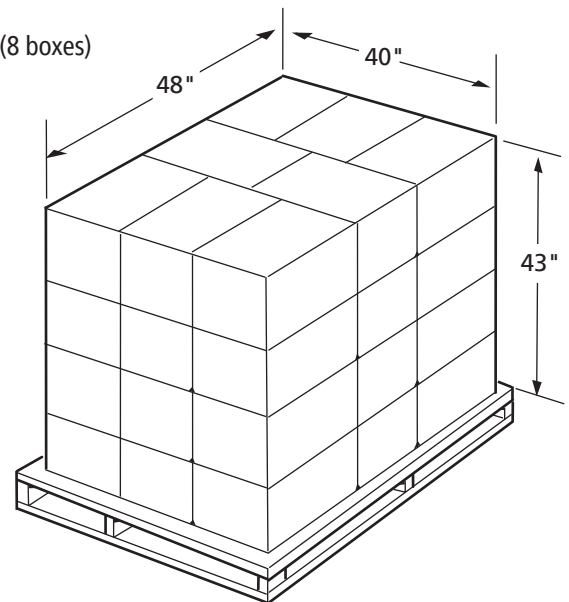

8203

Chemistry

Butyl Sealant

Form

3 lb Carton

Shelf Life

One year from the date of shipment.

Standard Disclaimer

The data presented is based on tests standard to the adhesive industry. Because we have no control over the application process or the substrates used by the customer, HMT can not certify the performance of the assembly the adhesive is used on. HMT will assume no responsibility for results obtained or for incidental or consequential damages arising from the use of this adhesive.



Hot Melt Technologies, Inc.
 No One Puts It Together Like HMT[®]

1723 W Hamlin Road, Rochester Hills, MI 48309 (248) 853-2011 www.hotmelt-tech.com

11/01/2024