



# BENCHMARK® 215-HVR

High Performance System

### Standard Features

- ▶ Microprocessor System Control
- ▶ Auto-Standby, Auto-Off
- ▶ Manual Standby
- ▶ Adjustable High Limit
- ▶ O.T. Diagnostics
- ▶ All Zone Temp Readout
- ▶ Temp Readout, °F or °C
- ▶ AC Drive Motor
- ▶ Accessory Output
- ▶ Cast Iron Pump w/ Steel Gears
- ▶ Tank Filter
- ▶ Pump Ready/Lock-out
- ▶ Precision Flow Control

### Common Options

- ▶ #921-011 Steel Cart
- ▶ #922-050 Spray Pattern Controller

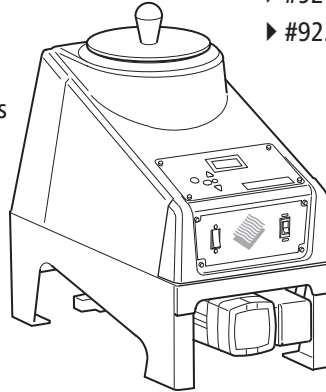

### Benchmark® Melt Unit 120v, 20 amp

DESCRIPTION	PART NUMBER P/N	TANK CAPACITY (APPROX.)	HOSE/GUN CAPABILITY
Benchmark® 215 ▶ HP System Control ▶ 43 rpm / PA-30 ▶ 100° F - 475° F	BM215-HVR4  ▶ Use XP Prefix for 220v	13 lb (2 Gal)	1

### Heated Hoses 120v ▶ Use XP Prefix for 220v

HOSE LENGTH	REGULAR HOSE P/N	SPRAY HOSE P/N
8 Ft.	DG0608-R	DG0608-S
12 Ft.	DG0612-R	DG0612-S
16 Ft.	DG0616-R	DG0616-S

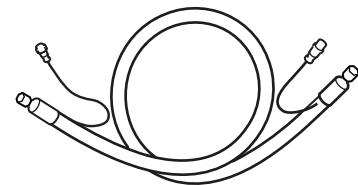

### Handguns & Automatic Guns 120v ▶ Use XP Prefix for 220v

CONFIGURATION	Standard Entry	Top Entry	In-Line	Automatic Gun
PART NUMBER #	DG-401-RS * DG-403-RS *	DG-403-RT *	DG-501-R * DG-503-R *	AV-600-RU

\* Handgun Swivel: 01 = Straight Swivel; 03 = Ball Swivel

▶ See Gun/Nozzle Pages for available Bead and Spray Nozzles

Effective Date: 12/12/2024  
All prices are subject to change without notice