

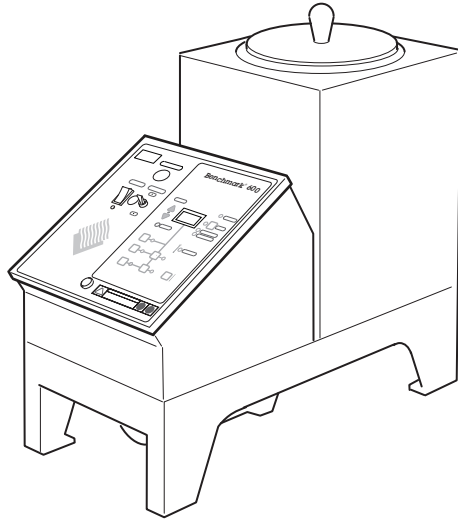

## BENCHMARK® 650

High Performance System

I.G. Sealant System



### Standard Features

- ▶ Manual Standby
- ▶ Auto-Standby, Auto-Off Timer
- ▶ Microprocessor Temp Control
- ▶ All Zone Temp Readouts
- ▶ Patented Modular Melt Tanks
- ▶ Power Cord
- ▶ Hardened Steel Gear Pumps
- ▶ High Torque AC Drive Motor
- ▶ Precision Flow Control

### Common Options

- ▶ #340-032 Key Lock
- ▶ #921-011 Steel Cart
- ▶ **#911-112 Hinged Lid, 10", Installed**
- ▶ See Load Alert Page

### Benchmark® Melt Unit 220v

DESCRIPTION	PART NUMBER P/N	TANK CAPACITY (APPROX.)	HOSE/GUN CAPABILITY
BM650	BM650-WS-F4	50 lb	1

### Handguns 220v

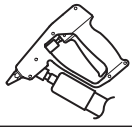

CONFIGURATION	Standard Entry 
PART NUMBER	XP-403-RS

### Heated Hoses 220v

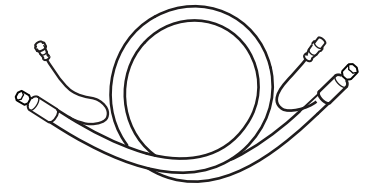
HOSE LENGTH	REGULAR HOSE P/N
8 Ft.	XP1008-HF
12 Ft.	XP1012-HF
16 Ft.	XP1016-HF



### Insulated Glass Gunning Tips Solid Brass

PART NUMBER	ORIFICE
156-098 	Tip Seat
156-IG3	3/16" Bead
-IG4	1/4" Bead
-IG5	5/16" Bead
-IG6	3/8" Bead
-IG7 	7/16" Bead
-IG8	1/2" Bead
-IG10	5/8" Bead
-IG12	3/4" Bead

### Standard Bead Extrusion Nozzles

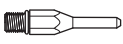
PART NUMBER	ORIFICE
156-022 	.090
156-047 	.090