

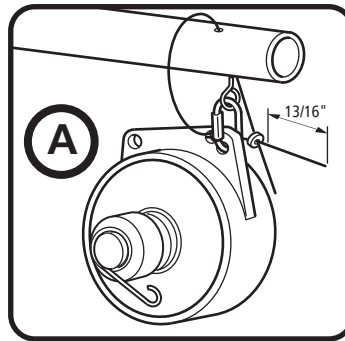

Boom & Balancer

933-001

Eye Bolt Installation

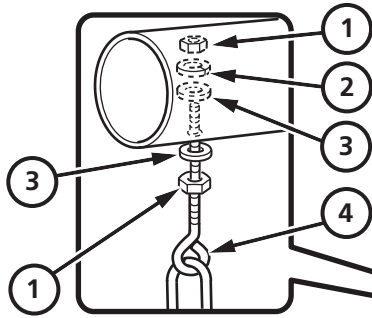

Feed safety wire through the extra hole in the boom arm and back through the extra balancer mounting hole as shown to the left. Install the clamp with at least 13/16" of wire protruding from the back of the clamp. Tighten clamp nuts to 2 Nm torque (approx. 1.5 ft-lbs)*.

BILL OF MATERIALS			
ITEM	DESCRIPTION	PART NO	QTY
1	Hex Nut 1/4-20	310-019	2
2	Lock Washer 1/4"	316-007	1
3	Flat Washer 1/4"	315-007	2
4	Eye Bolt 1/4-20 X 1"	300-015	1
5	Boom Arm	170-002	1
6	Height Adjustment Collar	300-013	1
7	Boom Stand	170-001	1
8	Hose Hammock	933-006	1
9	Tool Balancer	170-004	1

- Secure Boom Stand to work area.
- Insert Eye Bolt into Boom Arm using Flat Washer, Lock Washer and Hex Nut as shown.
- Install Height Adjustment Collar onto Boom Arm; leave it loose at this time.
- Insert Boom Arm into Boom Stand. Minimum engagement 6".
- Clip Tool Balancer to the Eye Bolt assembly just installed.
- Attach the Hose Hammock to the Tool Balancer using the Quick Link. Install safety wire as described above.

- Adjust the Boom Arm to the desired height and lock in place with the Height Adjustment Collar.
- Set working height with Stroke Limiter Clamp.

- To adjust Tool Balancer Tension, remove red cap.*
 - Use a large adjustable wrench and turn counter clockwise to increase tension.
 - To decrease tension press spring clockwise.

*See Tool Balance Manual for more information

